

TSUBAKI ZIP CHAIN LIFTER[®]



Innovative "lifting equipment" from Tsubaki

TSUBAKI Zip Chain Lifter

1. High-speed lifting Operates 3 to 10 times faster than hydraulic lifters

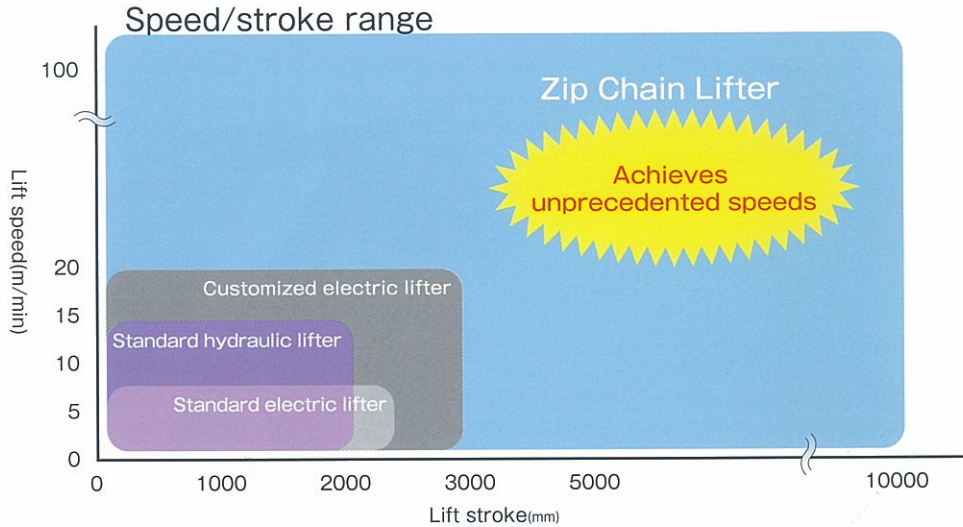

2. High-frequency operation supports high-frequency operation cycles

3. Superior endurance and significant reduction in maintenance labor-hours Still durable after more than one million lift cycles

4. High repeatable stopping accuracy at multiple points

5. Cleanliness No hydraulics and pneumatics used

6. Energy saving up to 50% more efficient than traditional hydraulic lifters

7. Type comparison

Comparison item	Zip Chain Lifter	Hydraulic lifter	Electric screw lifter	Comparison
Lift speed	0-100m/min	0-15m/min	0-15m/min	6 times or higher
Continuous (high-frequency) operation	Supported	Not supported (due to increase oil temperature)	Not supported (due to motor duty)	Supported
Durability (maintainability)	High	Low	Low	3.3 -20 times higher
Multiple stop positions	Easy	Difficult	Difficult	Well supported

A Zip Chain is a "unique chain that utilizes Tsubaki's chain technology to allow for applications involving pushing and pulling."

It is so named because it consists of two chains that interlock in a "zip"-like fashion to form a single column.

A Zip Chain Lifter is an innovative lifter that directly transmits lift thrust through Zip Chains.

Mechanism that transmits drive force more efficiently

Minimum load on scissor bearings and rollers

● Zip Chain Lifter

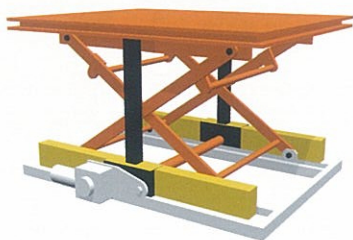

Outstanding durability

The Zip Chain supports the weight and thrust of the lift unit to inhibit large forces from acting on the scissor hinges or roller bearing.

Transmission of drive force more efficiently

The Zip Chain directly pushes the lift table so that motor torque can be transmitted without loss.

● Electric/hydraulic lifter

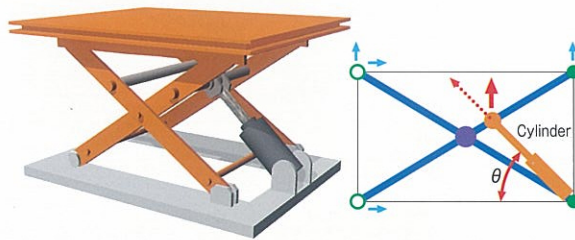

An electric/hydraulic lifter requires a large force (a force of $1/\sin\theta$ multiplier lift thrust) as the cylinder diagonally pushes the lift table at the lowest position. For example, a thrust of 5.8 times the lifter weight is needed when θ is 10 degree.

Lift speed that is proportional to the motor rotation speed

The speed is constant throughout the stroke range.

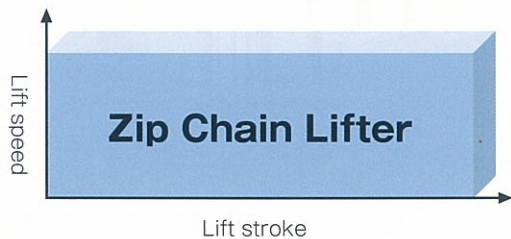

The speed differs throughout the stroke. The speed becomes slow in the middle.

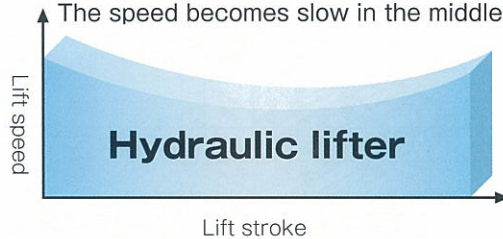

Simple multi-stage control mechanism

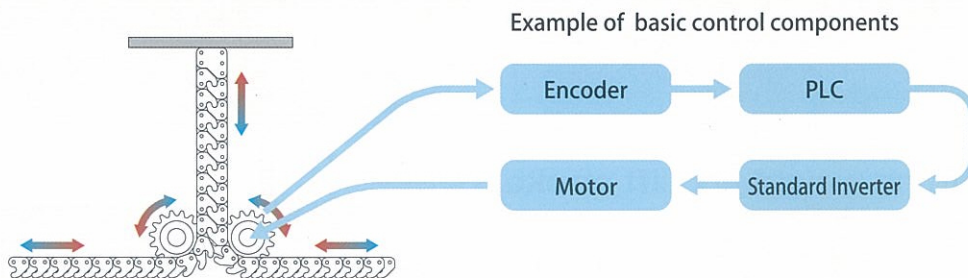

Custom designed lifters also available by request

Product

■ 1,000kg single-stage pantograph type

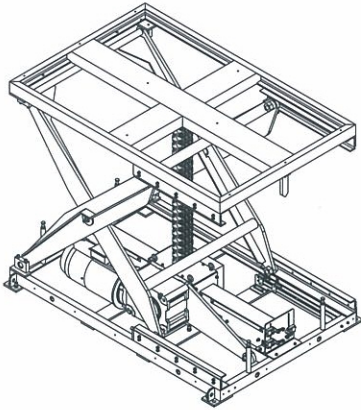

Allowable lifting weight	1,000 kg
Lift speed	14 m/min
Lift stroke	1,200 mm
Table size	1,100 × 2,000 mm
Minimum height	400 mm
Motor	5.5kW induction
Unit weight	870 kg

■ 400kg dual-stage pantograph type

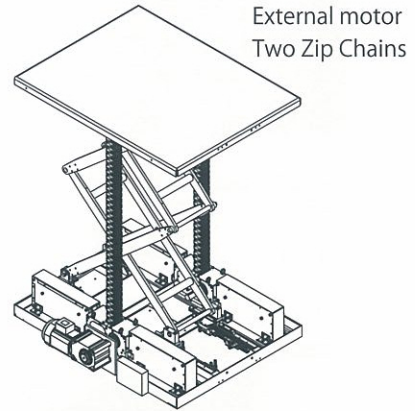

Allowable lifting weight	400 kg
Lift speed	20 m/min
Lift stroke	1,300 mm
Table size	1,000 × 1,300 mm
Minimum height	400 mm
Motor	3.7kW induction
Unit weight	650 kg

■ 300kg triple-stage telescopic type

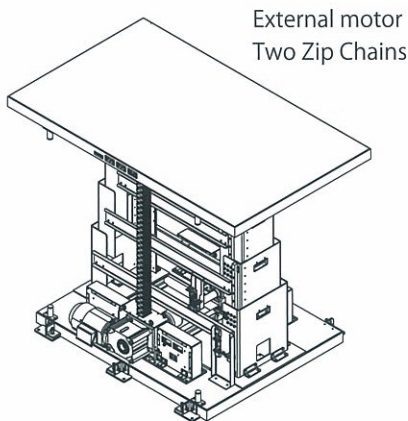

Allowable lifting weight	300 kg
Lift speed	13 m/min
Lift stroke	900 mm
Table size	1,200 × 1,700 mm
Minimum height	700 mm
Motor	1.5kW servo motor
Unit weight	840 kg

■ 650kg post type

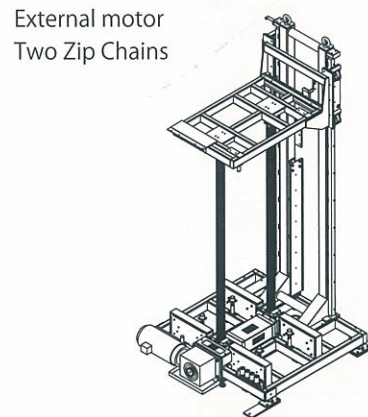

Allowable lifting weight	650 kg
Lift speed	40 m/min
Lift stroke	2,500 mm
Table size	1,350 × 1,550 mm
Minimum height	550 mm
Motor	11kW induction
Unit weight	1,400 kg

Allowable lifting weight and lift stroke

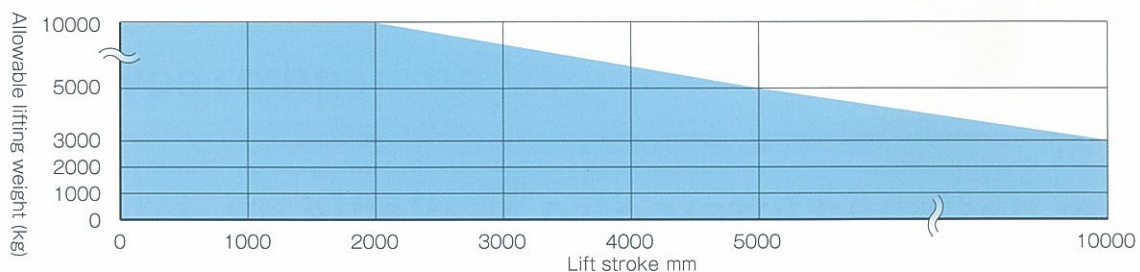

Application

Replacing a sloped belt conveyor

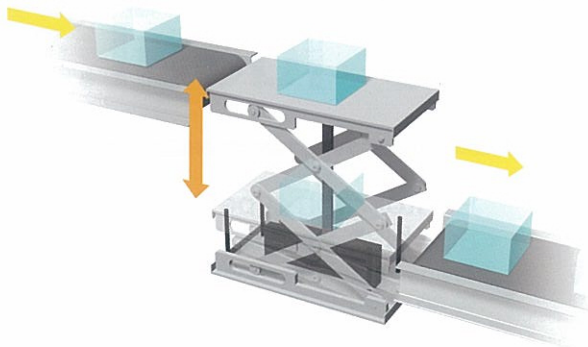

Transported items can "slip off" a sloped belt conveyor. The Zip Chain Lifter can secure transported items.

Lifting	Lifting weight	100 kg
	Lift speed	50 m/min
	Stroke	900 mm 7 sec/cycle
	Motor	Servo motor

Installed on an automatic guided vehicle (AGV)

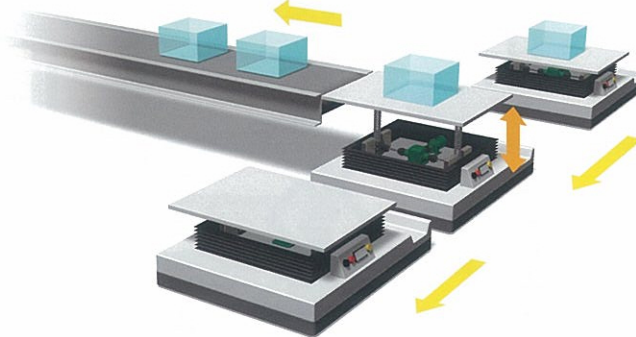

The ZIP Chain Lifter can be installed on an AGV with a small footprint. It eliminates the need to mount a hydraulic tank.

Lifting	Lifting weight	300 kg
	Lift speed	25 m/min
	Stroke	1250 mm 50 sec/cycle
	Motor	DC battery power supply

Lateral pushing and lifting

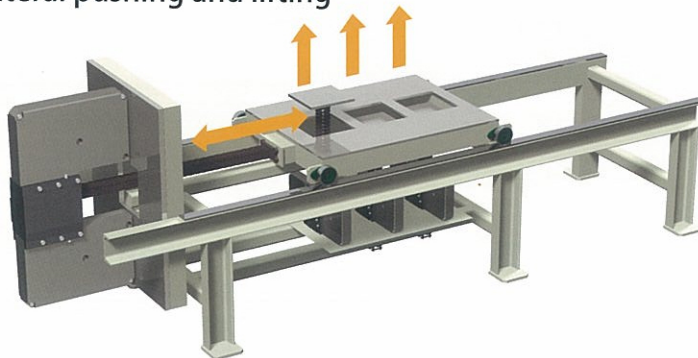

A Zip Chain Lifter is used to laterally push a dolly and supply workpieces. With no projection at the end, this compact equipment does not need any pits.

Lateral pushing	Lateral pushing force	200 kg
	Speed	12 m/min
	Stroke	1,700 mm
Lifting	Thrust	400 kg
	Stroke	800 mm

Injection molding machine

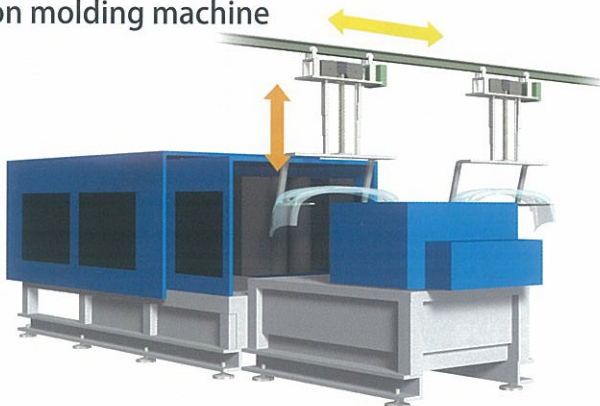

Unlike an air cylinder that requires space above for stroking, a Zip Chain unit allows for a reduction in the ceiling height of a building.

Suspension	Suspension weight	100 kg
	Lift speed	93 m/min
	Stroke	2,000 mm 15 sec/cycle
	Motor	Servo motor

Zip Chain Lifters enable and provide ideal work

Engine plant

Zip Chain Lifter provides ideal ergonomics. The height of a Zip Chain Lifter is flexible so that the worker can easily approach engines.

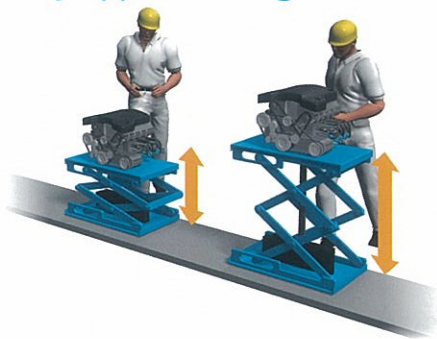

Lifting weight : 500kg Stroke : 900mm
Lift speed : 10 m/min

Pantograph-type, high-lift, and high-speed drop lifter
Transports undercoated vehicles to an overhead conveyor so that pits are no longer needed and the construction period can be significantly reduced.

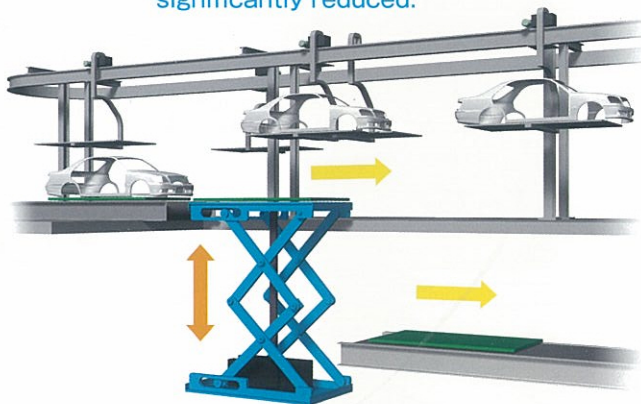

Lifting weight : 3,500kg Stroke : 7,000mm
Lift speed : 60m/min

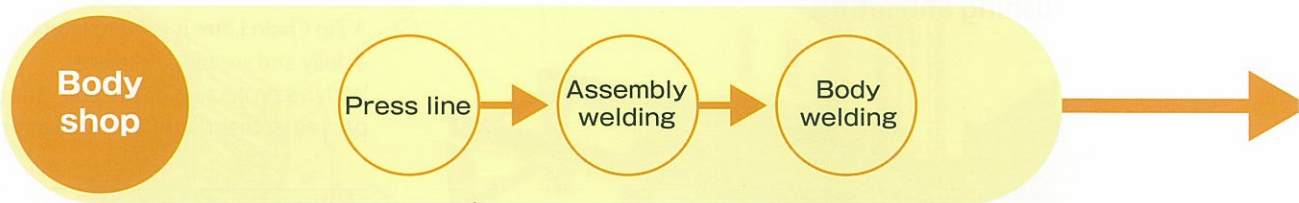

Suspending and transporting bodies to a welding line

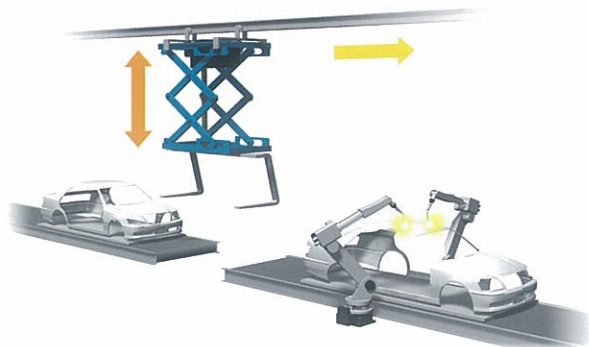

Lifting weight : 1,500kg Stroke : 2,500mm
Lift speed : 30m/min

Transporting doors, seats and instrument panels improves productivity (speed) and durability

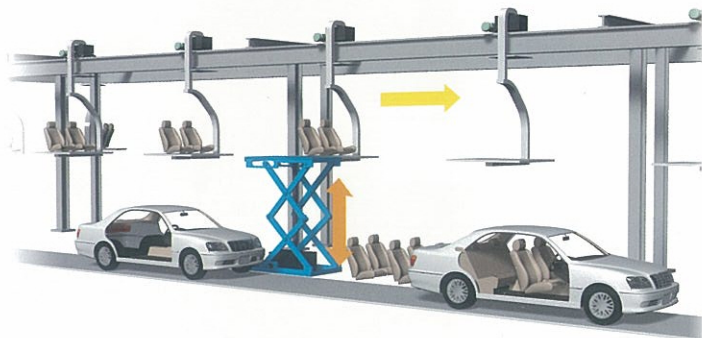

Lifting weight : 200kg Stroke : 4,000mm
Lift speed : 30m/min

factory automation (FA) flows.

Post-type, high-lift, and high-speed drop lifter

Transports coated vehicles to an assembly line

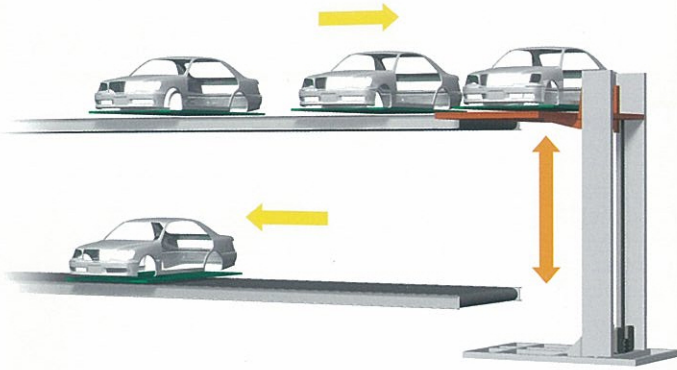

Lifting weight : 3,000kg Stroke : 5,000mm
Lift speed : 50m/min

Lifting engine units and rear suspension units supports

High-frequency operation (45 sec/cycle) significantly reduces maintenance labor-hours and improves durability

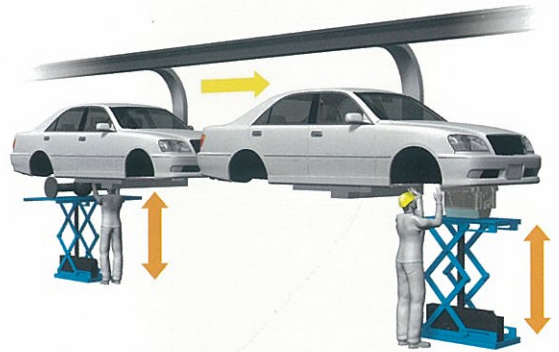

Lifting weight : 1,500kg Stroke : 1,500mm
Lift speed : 20m/min

Paint shop

Assembly shop

Finished vehicle



Filling brake fluid

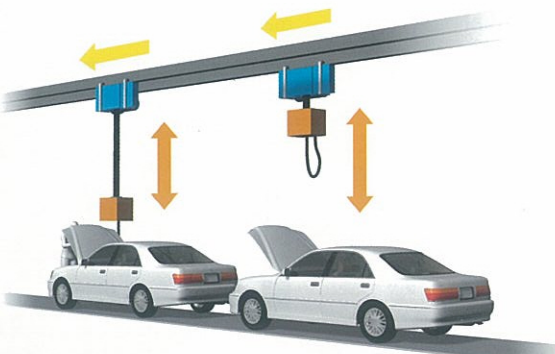

Lifting weight : 50kg Stroke : 3,000mm
Lift speed : 25m/min

Parts supply



High-speed vertical conveyance machine

Zip Lator



High-speed vertical conveyor with special Zip Chains provides an optimized flow line in the workplace

General specifications

Lifting height (H2)	Within 2,000mm	<small>*This can be increased to 3,000mm upon request. Please contact us for details.</small>
Lifted item weight	50kg (max.)	
Capacity	480times/hour	<small>*Varies depending on the lifted items</small>
Lift speed	80m/min	
Lower-limit level (H1)	600mm/800mm	
Frame materials	Aluminum + stainless steel (except for some parts)	
Exterior	Clear resin cover	
Control panel	Integrated / standalone	
Signal tower	2lights	
Drive unit	Special Zip Chain unit	
Lifting motor	850W servo motor	
Power supply	200VAC	

Features

1. Use of a Zip Chain achieving a lift speed of 80 m/min

The direct lifting mechanism that directly pushes a table increases the lift speed when compared to conventional lifting mechanisms.

2. Easy maintenance

Maintenance work including extended chain adjustment and chain replacement is significantly reduced.

The simplified internal structure also facilitates cleaning.

3. Sanitary design

A Zip Chain drive unit is installed at the bottom of the equipment. The frames and other parts are made of aluminum or stainless steel, in order to keep the inside of the case clean.

4. Gentle and strong

The servo motor control enables secure and gentle product transfer.

5. Space savings

The need to install an endless chain unit at the side of a table is eliminated, making a smaller footprint. The minimum size is 700 mm wide × 500 mm long.

6. Wide variety of options

*Induction conveyor (roller conveyor, belt conveyor)

*Table-top conveyor (roller conveyor, belt conveyor)

*Control panel (integrated, standalone)

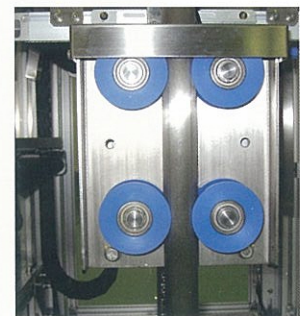

■ Guide roller assembly

The resin rollers are easily replaced, ensuring easy maintenance.

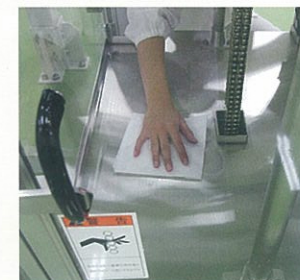

■ Lower stainless steel plate

The lower plate is made of stainless steel and is easily cleaned. The easy-to-clean structure improves both sanitary cleanliness and maintainability.

External dimensions

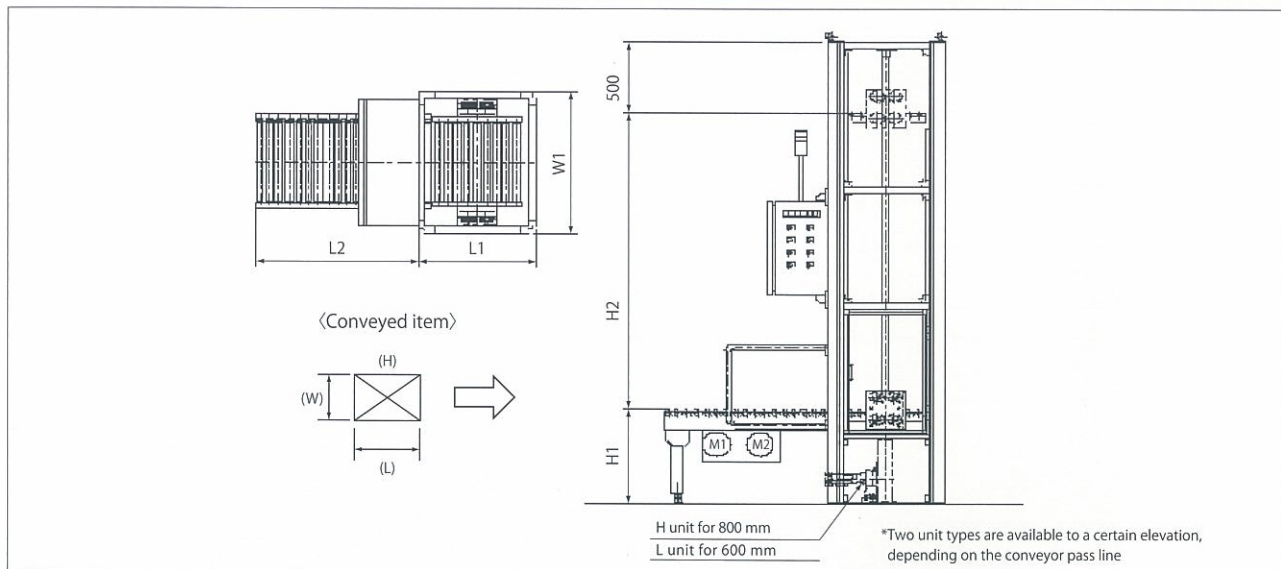

Model	Conveyed item size(mm) Width (W) × Length (L) × Height (H)	Standard equipment size (mm)				
		Width 1 (W1)	Length 1 (L1)	Length 2 (L2)	Conveyance height (H1)	Lifting height (H2)
ZLA3030	300 × 300 × 400	700	500	635	H (high) unit : 800	Within 2,000mm *This can be increased to 3,000 mm upon re- quest. Please contact us for details.
ZLA3050	300 × 500 × 400		700	1035		
ZLA3070	300 × 700 × 400		900	1435		
ZLA4040	400 × 400 × 400	800	600	835	H (high) unit : 800	
ZLA4050	400 × 500 × 400		900	1035		
ZLA5050	500 × 500 × 400	900	700	1035	H (high) unit : 800 L (low) unit : 600	
ZLA5070	500 × 700 × 400		900	1435		
ZLA7070	700 × 700 × 400	1100	900	1435		

*The shaded ZLA5050 model is illustrated in the following figure, "Footprint comparison."

Footprint comparison

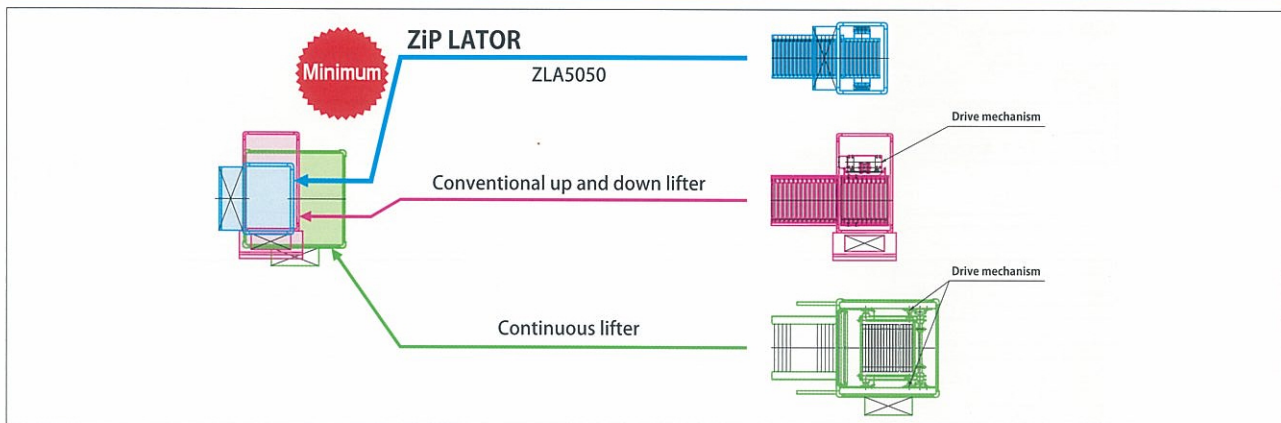

Conveying type

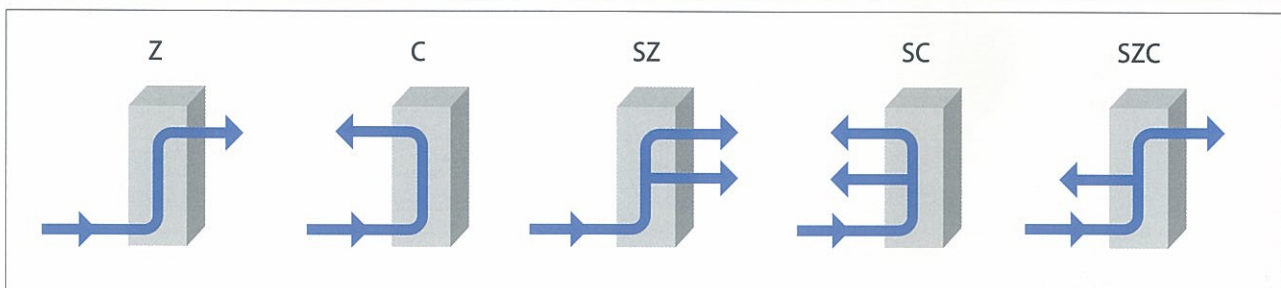

Zip Chain Lifter Inquiry Form

Fax this to the facsimile number listed on the back page of this brochure.

Date: / /

Company Name		Name (PIC)	
Zip Code		Section	
Address		E-mail Address	
Phone		Distributor	

1. Lifted item	(1) Fixed loading object	kg	Presence	<input type="checkbox"/> None <input type="checkbox"/> Conveyor <input type="checkbox"/> Jig <input type="checkbox"/> Others		
	(2) Transfer loading object	kg	Name			
			Size(mm)	Width	×Length	×Height
	Total weight((1)+(2))	kg	Center of gravity	Center of top plate Others()		
2. Stroke (mm)		3. Minimum height (mm)				
4. Table size (mm)		Width		Length		
5. No. of stop positions		<input type="checkbox"/> 2 (top, bottom)		<input type="checkbox"/> Multiple (up: positions / down: positions)		
6. Cycle time / lift speed						
· 2 stop positions (top and bottom)						
	Up	Stop	Down	Stop		
sec						
mm						
speed	m/min		m/min			
· Multiple stop positions						
	Up	Stop	Down	Stop	Repeating	
sec						
mm						
speed	m/min		m/min			
	Up	Stop	Down	Stop	Repeating	
sec						
mm						
speed	m/min		m/min			
Down						
7. Drive motor		<input type="checkbox"/> Servo motor <input type="checkbox"/> Induction motor		Encoder	<input type="checkbox"/> Y · <input type="checkbox"/> N	
Designated maker		<input type="checkbox"/> N/A (entrust to Tsubaki) <input type="checkbox"/> Manufacturer name()		Power supply / voltage	V	Hz
8. Operating hours		Hours/day		Days/year		
9. Stop positioning		★All lifters are equipped with a brake motor. Please let us know if you would like to use a worm reducer with the self-lock mechanism for safety.				
		<input type="checkbox"/> Use the self-lock mechanism of a worm reducer		<input type="checkbox"/> No need <input type="checkbox"/> Others		
10. Options		Four-faced bellows	<input type="checkbox"/> Y · <input type="checkbox"/> N	→ Black	<input type="checkbox"/> Clear <input type="checkbox"/> With fastener	
		Control panel	<input type="checkbox"/> Y · <input type="checkbox"/> N			
		Table-top conveyor	<input type="checkbox"/> Y · <input type="checkbox"/> N			
11. Will a person be riding along on top?		<input type="checkbox"/> Yes		<input type="checkbox"/> No		

Status Under	<input type="checkbox"/> Consideration	<input type="checkbox"/> Planning	<input type="checkbox"/> Conceptualization
Expected ordering timing	/	Desired delivery	/
No. of units	unit(s)	Expected Zip Chain Lifter feature	<input type="checkbox"/> High speed <input type="checkbox"/> High frequency <input type="checkbox"/> Long life <input type="checkbox"/> Stopping accuracy <input type="checkbox"/> Non-hydraulic

12.Lifter type

Pantograph type Telescopic type Post type

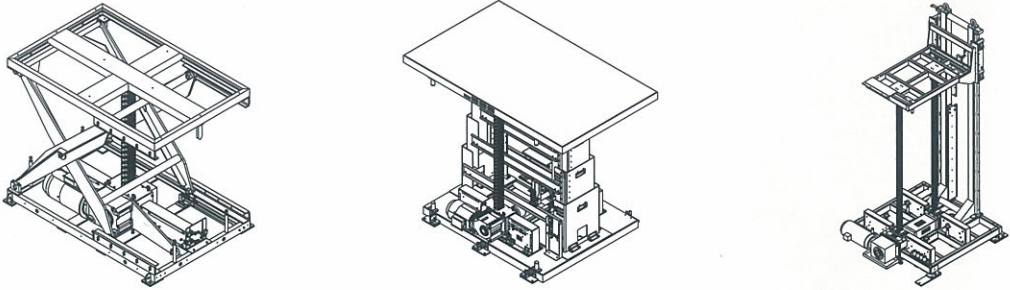

13.Motor layout Embedded drive component within lift table Need No need

*Please suggest the available motor position and space in case of "No need."

Pantograph type Post type

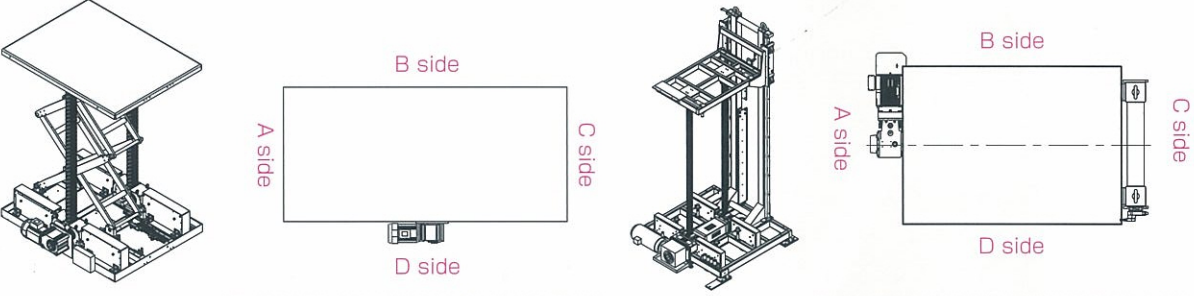

*In this figure, the motor is located at the D side. *In this figure, the motor is located at the A side.

A side: _____ mm C side: _____ mm
 B side: _____ mm D side: _____ mm

14.Transfer Yes No

*In case of "Yes," please fill out the table below.

	Direction a · b · c · d	Load weight kg	Height mm
Carry in			
Carry out			

Carry in → Carry out ←

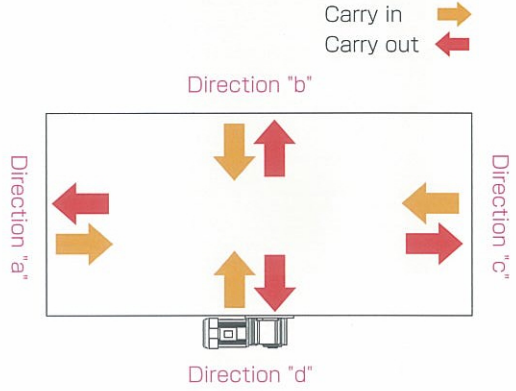

Options

■ Control panel

Automatic/manual switching
External input/output terminals



■ Bellows

A four-faced bellows prevents the entry of foreign substances into the lifter body when the table is moved up and down.



■ Automatic lubricator



52800 Pontiac Trail, Wixom, MI 48393 | 248.446.0118 | www.centralconveyor.com



TSUBAKIMOTO CHAIN CO. Nakanoshima Mitsui Building, 3-3-3, Nakanoshima, Kita-ku, Osaka 530-0005

Module Business Department

Tokyo Office: Taiyo Seimei Building, 2-16-2 Konan, Minato-ku, Tokyo 108-0075, Japan

Phone: (03) 6703-8408 Facsimile: (03) 6703-8412

Osaka Office: Daido Seimei Esaka Building, 1-23-101 Esaka-cho, Suita, Osaka 564-0063, Japan

Phone: (06) 7638-1329 Facsimile: (06) 6387-0821



The Tsubaki Eco Link logo is used only on products that satisfy the standards for environmental friendliness set by the Tsubaki Group

Tsubaki company website
<http://www.tsubakimoto.jp>

■ Notice

The specifications and dimensions are subject to change for improvement. Please contact us before beginning design.

© All the contents in this document are copyrighted by us. Unauthorized reproduction is strictly prohibited.

The logos, brand names, or product names in this catalog are trademarks or registered trademarks of Tsubakimoto Chain Co. and its subsidiaries in Japan, US and other countries.